

SMA Series

DIRECT SOLDER FOR SEMI-RIGID CABLE

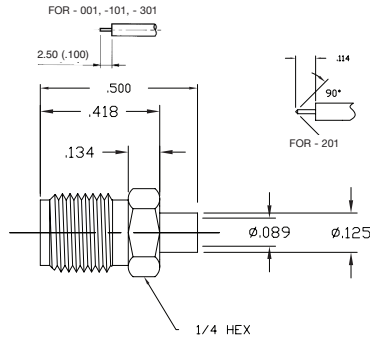
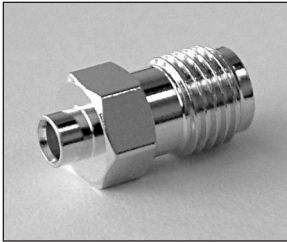

STRAIGHT CABLE JACK

PART NUMBER	CONTACT	CABLE
705517-001SMA	NON-CAPTIVE	.141 DIA. S/R
705524-101SMA	NON-CAPTIVE	.086 DIA. S/R
705517-301SMA	CAPTIVE	.141 DIA. S/R
705524-201SMA	CAPTIVE	.086 DIA. S/R

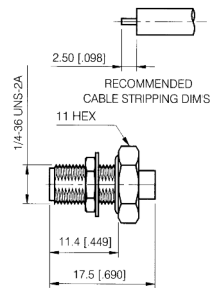
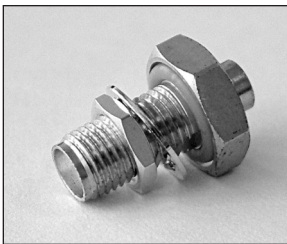

BULKHEAD FEED THROUGH CABLE JACK

PART NUMBER	CABLE
705528-101SMA	.141 DIA. S/R
705529-101SMA	.086 DIA. S/R

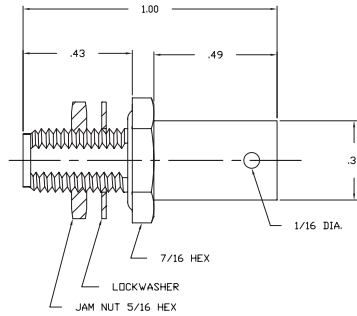
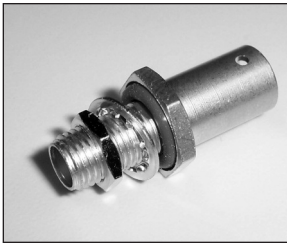

BULKHEAD FEED THROUGH CABLE JACK

PART NUMBER	CABLE
705543-101 SMA	.250 S/R
705543-201 SMA	.250 WP S/R

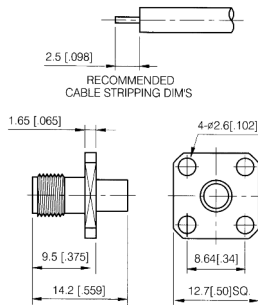
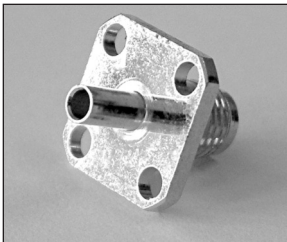

PANEL MOUNT CABLE JACK-4 HOLE SQUARE FLANGE

PART NUMBER	CABLE
705518-001SMA	.141 DIA. S/R
705521-101SMA	.086 DIA. S/R

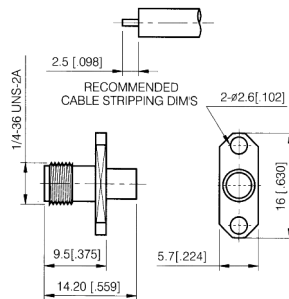
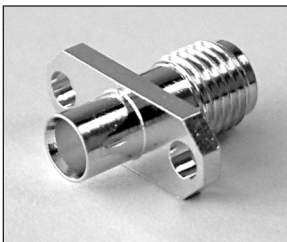

PANEL MOUNT CABLE JACK- 2 HOLE SQUARE FLANGE

PART NUMBER	CABLE
705525-001SMA	.141 DIA. S/R
705526-001SMA	.086 DIA. S/R