

RoHS
COMPLIANT

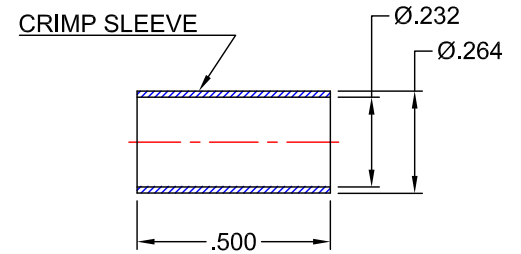
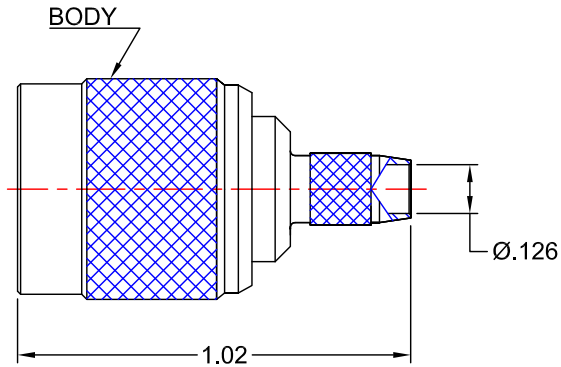

NOTES:

INTERFACE CONFORMS TO MIL-PRF-39012
AND MIL-STD-348 TNC SERIES

ELECTRICAL:

NOMINAL IMPEDANCE: 50Ω
FREQUENCY RANGE: DC TO 11 GHz

MATERIALS:

INSULATOR: TEFLON PER ASTM-D-1710
CONTACT, BODY, & COUPLING NUT: 360 ALLOY BRASS 1/2 HARD PER ASTM-B-16
GASKET: SILCONE RUBBER PER ZZ-R-765
CRIMP SLEEVE: 360 ALLOY BRASS PER ASTM-B-16

FINISHES:

CONTACT: GOLD PLATE PER MIL-DTL-45204
BODY: NICKEL PLATE PER QQ-N-290

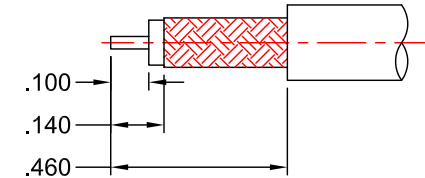
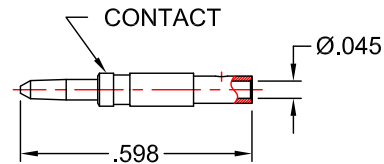

RECOMMENDED STRIPPING DIMENSIONS

PROPRIETARY NOTICE

THIS DRAWING AND DESIGNS AND IDEAS EMBEDDED IN THE DEVICE TO WHICH IT RELATES AND THE METHOD OF PRODUCING THE DEVICE SHALL NOT BE EMPLOYED COPIED OR DISCLOSED TO ANYONE IN ANY MANNER WITHOUT THE WRITTEN CONSENT OF AN EZ FORM COMPANY OFFICIAL

APPD. DATE	T.D. DATE	
4/4/17	4/4/17	
BY DATE	J.N. DATE	
4/4/17	4/4/17	
DESCRIPTION	INITIAL RELEASE	
REV.	-	

UNLESS OTHERWISE SPECIFIED:

DIMENSIONS ARE IN INCHES:
TOLERANCES: NONE

SCALE
2:1

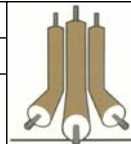

EZ Form Cable Corporation
285 Welton Street
Hamden, CT 06517
WWW.ezform.com

MATERIAL	SEE NOTES	
FINISH	SEE NOTES	
DRAWN	DATE	CHECKED
J.N.	4/4/17	T.D.
DATE	4/4/17	DATE
4/4/17		4/4/17
APPROVED	DATE	SHEET 1 OF 1
A.T.	4/4/17	

TITLE	TNC STRAIGHT PLUG FOR RG-142/223 CABLE		
A	CODE IDENT.	701041TNC	REV.
	9W826		-