

**RoHS**  
COMPLIANT

**NOTES:**  
INTERFACE AND ENVIRONMENTAL REQUIREMENTS  
CONFORM TO MIL-PRF-39012 AND MIL-STD-348 SMA SERIES

**MATERIALS:**  
INSULATOR: VIRGIN WHITE TEFLON PER ASTM-D-1710  
BODY, COUPLING NUT, CONTACT, & CRIMP SLEEVE:  
BRASS PER ASTM-B-16  
INSULATOR: VIRGIN WHITE TEFLON PER ASTM-D-1710  
GASKET: SILICONE RUBBER PER ZZ-R-765  
RETAINING RING: BERYLLIUM COPPER PER ASTM-B-196B

**FINISHES:**  
BODY, COUPLING NUT, CONTACT, & CRIMP SLEEVE:  
GOLD PLATE PER MIL-G-45204

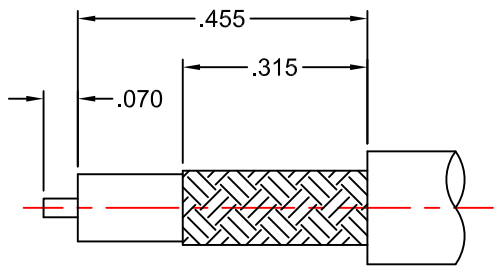
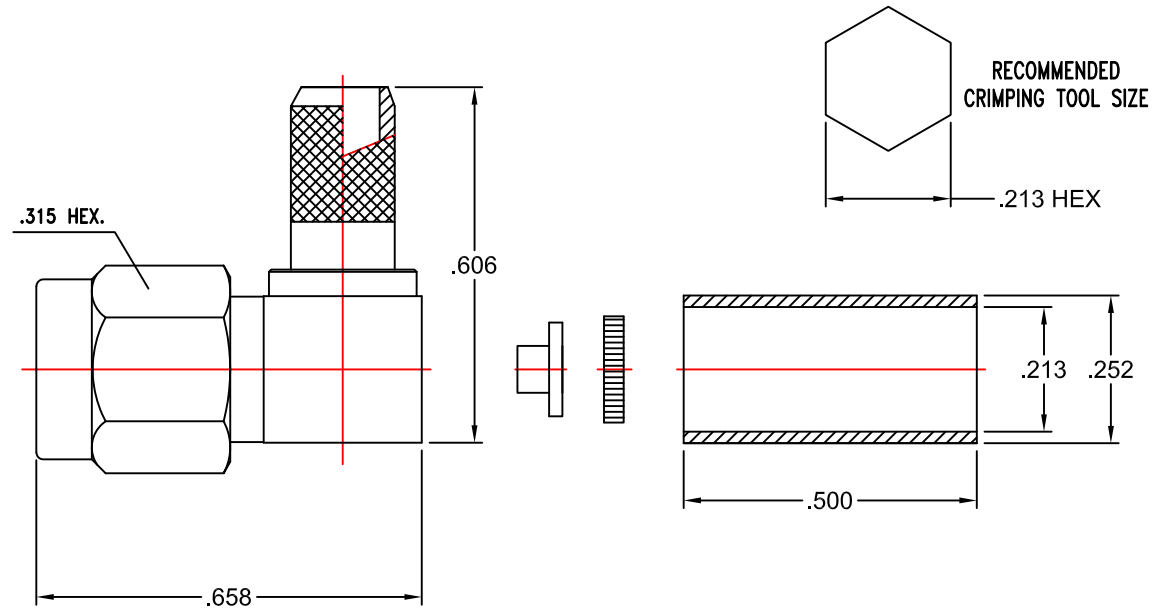

RECOMMENDED  
CABLE STRIPPING DIMS

**PROPRIETARY NOTICE**

THIS DRAWING AND DESIGNS AND IDEAS EMBEDDED IN THE DEVICE TO WHICH IT RELATES AND THE METHOD OF PRODUCING THE DEVICE SHALL NOT BE EMPLOYED COPIED OR DISCLOSED TO ANYONE IN ANY MANNER WITHOUT THE WRITTEN CONSENT OF AN EZ FORM COMPANY OFFICIAL

APPD.	T.D.	
DATE	11/2/15	
BY	T.D.	
DATE	11/2/15	
DESCRIPTION	INITIAL RELEASE	
REV.	-	

<b>UNLESS OTHERWISE SPECIFIED:</b>			
DIMENSIONS ARE IN INCHES:		SCALE	
TOLERANCES:		3:1	
DECIMALS:	FRACTIONS: ± 1/64		
2-PLACE ± .010	ANGLES: ± 3°		
3-PLACE ± .005			
MATERIAL: SEE NOTES			
FINISH: SEE NOTES			
DRAWN	DATE	CHECKED	DATE
T.D.	11/2/15	AT	11/2/15
APPROVED	DATE	SHEET	OF
F.V.	11/2/15	1	1

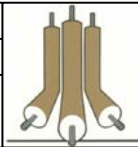

**EZ Form Cable Corporation**  
285 Welton Street  
Hamden, CT 06517

TITLE			
SMA RIGHT ANGLE PLUG FOR RG 58U CABLE			
A	CODE IDENT.	705558-001 SMA	REV.
	9W826		-