

NOTES:  
 INTERFACE CONFORMS TO MIL-PFR-39012 SMA SERIES

MATERIALS:  
 BODY - BRASS PER ASTM-B-16  
 JAM NUT - BERYLLIUM COPPER PER ASTM-B-196  
 CONTACT - PHOSPHOR BRONZE  
 LOCKWASHER - TEFLON PER ASTM-D-1710  
 INSULATOR - SILICON PER ZZ-R-765  
 GASKET - ANNEALED COPPER  
 CRIMP SLEEVE -

FINISHES:  
 BODY, CONTACT - GOLD PLATE PER MIL-G-45204  
 NUT, & LOCKWASHER NICKEL PLATE PER QQ-N-290  
 CRIMP SLEEVE

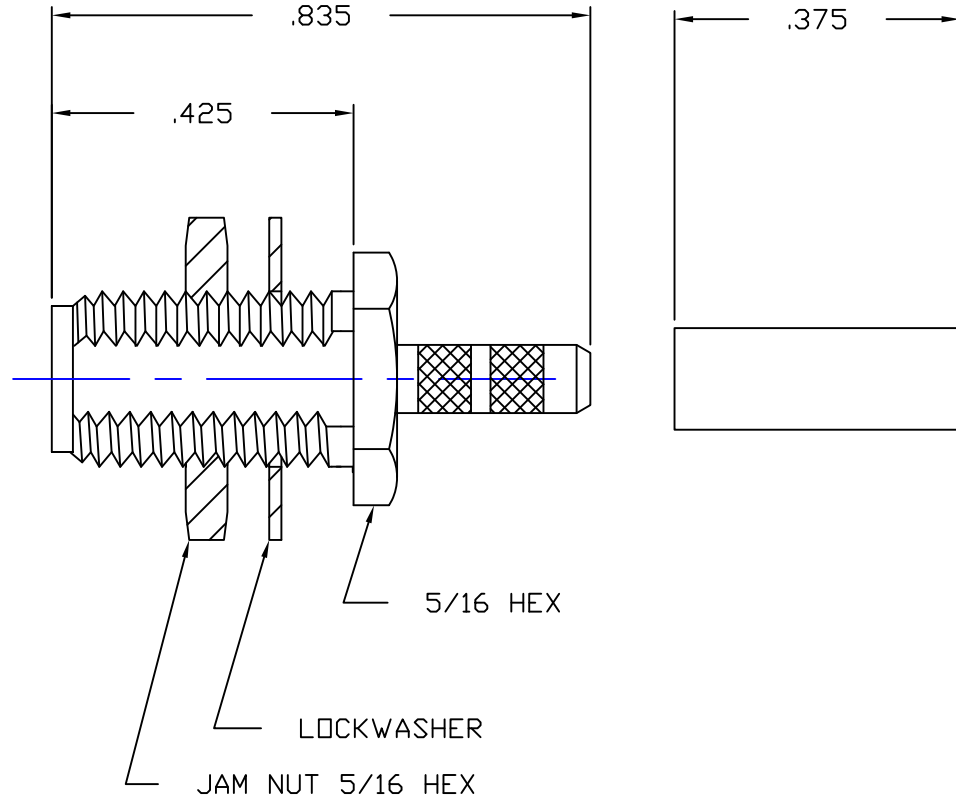
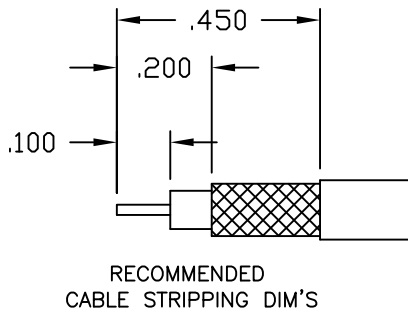

ORDERING P/N 705566-102SMA

THIS DRAWING THE DESIGNS AND IDEAS EMBEDDED IN THE DEVICE TO WHICH IT RELATES AND THE METHOD OF PRODUCING THE DEVICE SHALL NOT BE EMPLOYED COPIED OR DISCLOSED TO ANYONE IN ANY MANNER WITHOUT THE CONSENT OF AN EZ FORM COMPANY OFFICIAL

APPD		
BY		
DATE		
DESCRIPTION		
REV.		

<b>UNLESS OTHERWISE SPECIFIED:</b>			
DIMENSIONS ARE IN INCHES:		SCALE	
TOLERANCES:			
DECIMALS:	FRACTIONS ± 1/64		
2-PLACE ± .010	ANGLES ± 3°		
3-PLACE ± .005			
MATERIAL:			
FINISH:			
DRAWN	DATE	CHECKED	DATE
P.J.P.	4-30-03	J.A.B.	4-30-03
APPROVED	DATE	SHEET	OF
T.R.	4-30-03		

<b>EZ FORM</b> <b>CABLE CORPORATION</b> <b>HAMDEN, CT. 06517</b>			
TITLE SMA BLKD. MOUNT JACK FOR RD316 CABLE CRIMP TYPE			
A	CODE IDENT.		REV.
	9W826	CD-705566-102	—